

CENTRAL SLURRY SYSTEMS

Model 911

Installation and Operating Instructions
Revised 6/04/08



PRACTICAL SYSTEMS, INC.
11617 Prospect Road • Odessa, FL 33556
(800) 237-8154 • Fax (800) 330-3800
(727) 376-7900 • Fax (727) 372-1900

INSTALLATION AND OPERATING INSTRUCTIONS

INSTALLATION

1. Locate the slurry system as close to the surfacing machines as possible to insure proper drainage back into the main slurry tank. The slurry system should be easily accessible. It may be in line with the polishers at either end, in the middle of the line or directly behind the first polisher.
2. Install a slurry feed line to supply the polishers. (Diagram 1)
 - a. This line should be made using 3/4 inch PVC or other suitable material.
 - b. Use 1 inch vinyl tubing (supplied) to make the connection between the filter housing and the feed line.
 - c. Install a "T" in the feed line at each polisher.
 - d. At this point, reduce from the "T" to the supply line on the polishers. Manual or solenoids valves may be installed if needed at this point to control slurry flow. It is necessary to have valves at each machine so if a cylinder machine is taken off line for repair, you can manually shut polish flow off.
3. Install drain line to route slurry back to slurry system. This drain line may be installed in front of the polishers, however, it is recommended for ease of installation and maintenance, that the slurry drain be installed behind polishers. (Diagram 1)
 - a. Assemble line with 2 inch PVC or other suitable material with sweeping or sanitary "T"s making sure the sweep is toward the slurry system.
 - b. Support or attach drain to the polishers so the drain line is straight with no bows or sags. The drop is approximately 1 inch for every 3 feet of drain line.
 - c. Install a 45 degree elbow on the drain line at the slurry system so slurry is directed through the screen.
 - d. You may want to install a removable cap at the beginning of the drain line so you have access if something becomes lodged.
 - e. Connect bowl to slurry drain "T" with 3/4 inch vinyl hose. It is recommended this drainage hose be covered with a foam insulation tube to avoid heat from the cylinder machine. It is important that the vinyl hose falls below the inlet of the main drain.

CAUTION: Make sure vinyl hose coming from the bowl and passing through the cylinder machine is kept free of any moving parts that could rub a hole in the hose.

4. It is recommended a three way or pool valve be installed in the drain line just prior to the slurry system. This will allow rinse water from the bowls to be diverted away from the slurry system. Cylinder machines should be rinsed and cleaned daily with warm water.

Diagram 1

Central Slurry Feed & Drain Lines (Rear View)

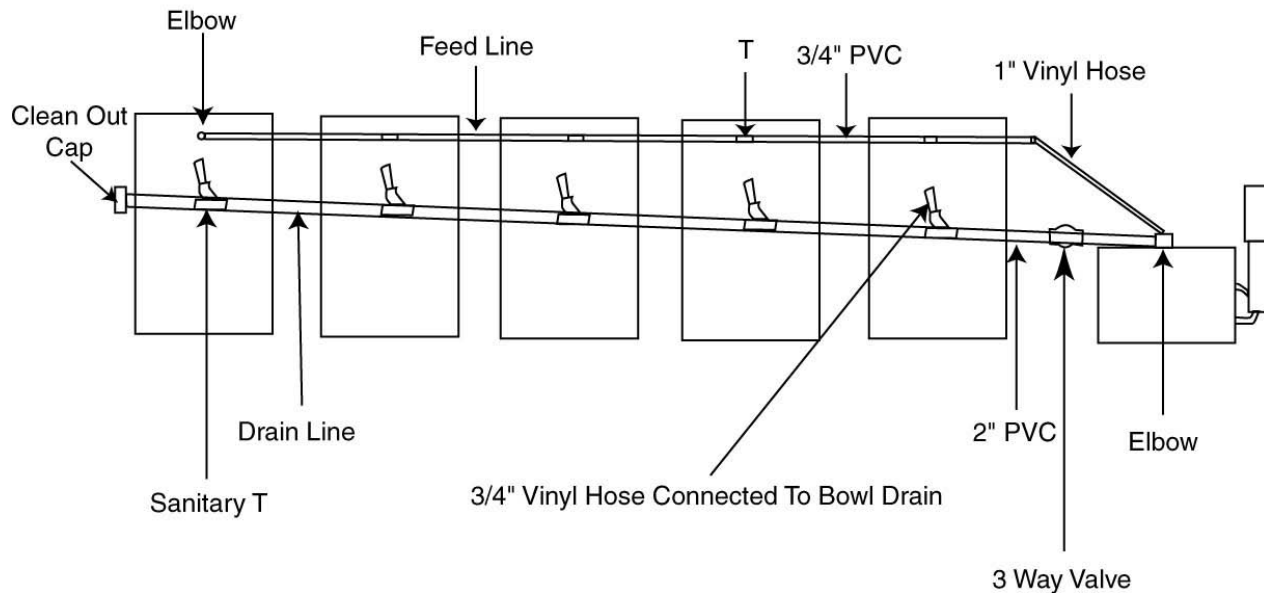

ELECTRICAL

The pump on the 911 central slurry system is wired for 115 volts when shipped from the factory but may be converted to 230 volts. See wiring instructions on pump motor.

CAUTION: Always recheck motor rotation.

CAUTION: This equipment should be connected to an electrical outlet equipped with GFI (ground fault interrupt) to prevent possible electrical shock.

Pump Disassembly

1. Remove plug from drip cover on top of the motor.
2. Remove screw 1 and cover 2.
3. Insert screwdriver into motor end shaft slot and unscrew impeller 4; standard RH thread.
4. Remove screws 6, 7 and body assembly 5.

Pump Inspection

1. Check all internal and external threads for damage or stripped thread.
2. Replace all gaskets and O-rings if necessary.
3. Check impeller for cracks, abrasions and distortion.
4. Check shaft for run out and chemical attack.

ELECTRICAL (Cont.)

Pump Reassembly

1. Secure body assembly 5 to motor 9 with screws 6, 7.
2. Insert screwdriver into slot in the end of the motor shaft and thread impeller 4 onto motor shaft (RH tread).
3. Replace O-ring 3.
4. Secure cover 2 to body assembly 5 with screws 1.

Replacement Parts (1/2 HP)

Motor/Pump Assembly.....	2658
5 Body Assembly	2658-6
4 Impeller Assembly	2658-1
3 O-ring	2658-2
2 Inlet Cover	2658-4
1 Cover Screws	2658-5

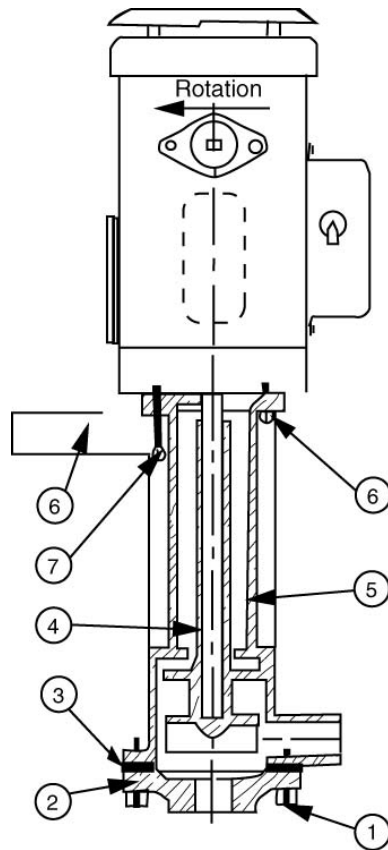

VALVE SETTINGS

There are three valves on the 911 Slurry System (shown in diagram below):

- #1 **Main Line Valve** - This valve may be closed when flushing out the reservoir and pump, otherwise this valve is open.
- #2 **Bypass Valve** - This valve is used to control the bypass of polish, thus reducing the volume and pressure at the polishers. It aids in the chilling process if the bypass valve is partially open, allowing the polish to be recirculated back to the tank.
- #3 **Drain Valve** - This valve is used to empty the slurry that can not be pumped from the bottom of the reservoir. This valve is normally closed.

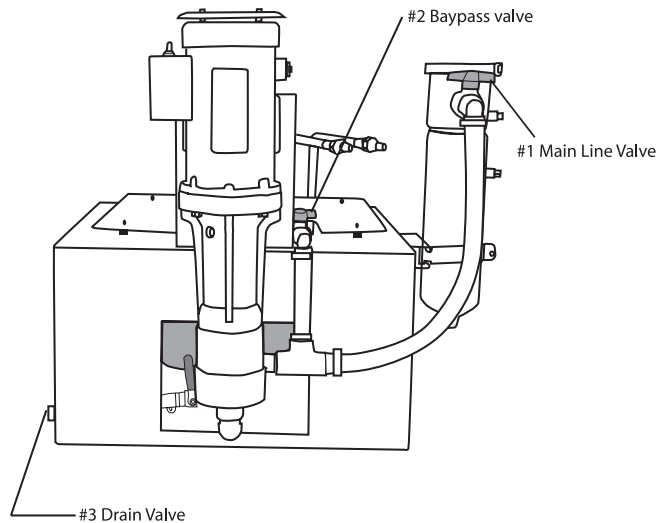

CAUTION: When running the pump with the cylinder machines off, make sure the bypass valve is in the open position.

OPERATION

1. Make sure the Drain Valve at the bottom of the pump is closed.
2. Check the filter canister making sure it contains a filter bag.
3. Place the heat exchange coil in slurry tank and connect to chiller using vinyl hose.
4. Follow chiller instructions for charging chiller and coil.
5. Fill the slurry tank with water to a level of 2 inches from the top of the tank.
6. Turn pump on and check system and plumbing for possible leaks. This is a good time to adjust the Vertical Bypass Valve. If the pressure or splash is too great then open the bypass. If you do not have enough polish at the polishers, close the bypass valve till you have reached the desired flow rate. It aids in the chilling process if the bypass valve is partially open, allowing the polish to be recirculated back to the tank.
7. After it has been determined there are no leaks, the water can be drained either by connecting a garden hose to the Drain Valve located at the bottom of pump and gravity drain or disconnect the 1 inch vinyl tubing from the slurry feed line and use the pump to remove as much water as possible.

CAUTION: Secure vinyl hose before turning pump on. Do not continue to run pump after flow has stopped. This could cause damage to pump.

8. The pump will not be able to remove all of the water. The balance left in reservoir may be drained with the Drain Valve on the bottom of the pump.
9. Next drain the filter housing. Disconnect the vinyl hose and let any remaining water in the housing and lines drain out. Remove filter bag and turn inside out and rinse off any foreign material. Rinse out housing and return filter bag back to original position.
10. Make sure drain valve is closed.
11. Wipe out inside of reservoir and you are ready to charge system with slurry.

Charging the System

1. Fill the slurry tank with polish or emery.
2. Follow the "Morning Maintenance" procedures listed below to mix tank.
3. Once mixed, turn on pump and allow the filter and lines to fill.
4. Add polish or emery so it is 2 to 4 inches below the top of the tank. Care should be taken not to overfill. If the level in the slurry tank is too high when the system is operating, the tank may overflow when the pump is shut off and polish drains back.
5. Make sure screen is in place on top of the tank and install splash cover.
6. The elbow on the return line should be inserted through the rubber flap in center of splash cover.

MAINTENANCE

Daily Maintenance (IMPORTANT)

Morning Maintenance

1. Each morning prior to operation, adjust the bypass valve to fully bypass and close off the main valve.
2. Turn the pump on and recirculate the polish for 10 minutes to thoroughly mix the settled solids.
3. Take baume reading

Afternoon Maintenance

1. Each day, remove filter bag, there should only be 1/2 inch to 1 inch of debris (pad nap) in the filter bag. Turn it wrong side out and rinse off.
2. Return the filter bag to the housing.

CAUTION: Do not let slurry stand in housing overnight as this may cause premature plugging of the filter.

3. It is recommended a three way or pool valve be installed in the drain line just prior to the slurry system. This will allow rinse water from the bowls to be diverted away from the slurry system. Cylinder machines should be rinsed and cleaned daily with warm water.

MAINTENANCE (CONT.)

Monthly Maintenance

1. It is recommended to flush the entire system, including rinse bowls and drain lines with Opti-Clean (part #610) every month. This will eliminate a buildup of settled polish and hardened solids in the system.

Tank & Pump Cleaning

1. Remove the polish as described earlier.
2. Close the valve in the main line between pump and filter and open bypass valve all the way.
3. Flush with warm water, turn on pump and let the water circulate.
4. Drain the dirty water by opening valve on bottom of pump.
5. Be sure to readjust bypass valve and open main line valve. You are now ready to recharge the system.

The old slurry and dirty water from cleaning the system should be processed by the PAN HANDLER waste water treatment system for disposal. If you do not have a PAN HANDLER and would like information on this system, please contact us or visit our website at www.LookToPSI.com.

Changing Slurry

1. Slurry can be drained either by connecting a garden hose to the Drain Valve located at the bottom of pump and gravity drain or disconnect the 1 inch vinyl tubing from the slurry feed line and use the pump to remove as much slurry as possible.

CAUTION: Secure vinyl hose before turning pump on. Do not continue to run pump after flow has stopped. This could cause damage to pump.

2. The pump will not be able to remove all of the slurry. The balance left in the reservoir may be drained with the Drain Valve on the bottom of the pump.
3. Wipe out inside of the reservoir and you are ready to charge system with slurry.
4. Follow charging slurry directions listed on page 6.

It is highly recommended during polish changes to run warm water through the entire plumbing system to clean out all the lines of polish residue.

If you have any problems or questions with the installation or operation of the Central Slurry System, please call us toll free at 800-237-8154 or 727-376-7900 and we will be happy to assist you.